

PROGRAMME SETTINGS – CONTINUATION

HEATING INSTALLATION SETTING

Menu → Setting → Install.

- A/ **Heating setting:** adjust **floor type** (choose from the attached list), **Adaptive** (switching on the function causes the system heats before returning home, **PI controller** (switching it on causes the heating system accurately reaches the target temperature), **First warning**. It is a first heating function. It must be activated during the first time the room floor is heated. The thermostat has this functionality for 21 days and then it will automatically switch off drying of the floor. This function can be switched off at any time.
- B/ **Set offset:**
Its aim is to calibrate the regulator's temperature. For the room and floor sensors the adjustment is possible within -8 to +8°C range.
- C/ **Program period set:** The 24 hour day can be divided into 4 or 6 adjustment periods.
Default setting of the day is 6 periods.
- D/ **Set sensor** (floor sensor adjustment). It is necessary to choose the sensor used in the floor. The regulator enables the application not only of a floor sensor included in the set with a regulator (SASWELL 100k) but also a sensor by other producers. The regulator cooperates and the following sensors can be chosen: SASWELL 100k, SASWELL 10k, DEVI 15k, OJ12k, Eberle 33k, Ensto 47k, FENIX 10k, TYCO 10k, Teplolux 6K8, Warmup 12k, aube 10k.
- E/ **Reset.** It causes the return to default settings. YES confirmation causes the return to the default settings.
In case the expected temperature is higher than the real one, an icon meaning heating will appear on the screen:



TIME SETTING

Menu → Time (Date setting) → Next (Hour setting).

Adjust date by means of arrows up / down (day/month/year or year/month/day). By means of Next (Dalej) function we pass to hour adjustment (hour/minute/second). The **Next** function helps to choose day format, mode, 12 hour or 24 hour format. Confirm by **Apply**.

In case of power supply failure the clock resets and it is necessary to adjust date and time again.

ERROR MESSAGES

The following messages can be displayed:

- „**The floor temperature sensor short-circuit. Please check it.**” It is necessary to check if the floor sensor cable insulation is damaged or the sensor wires are short circuited.
- „**The floor temperature sensor open circuit. Please check it.**” It is necessary to check the wire connection of the external sensor to the regulator. Check if the external sensor's wire are not broken.
- „**The room temperature sensor short-circuit. Please check.**”- It is necessary to check if the sensor protruding from the bottom of the casing is damaged.
- „**The room temperature sensor open circuit. Please check it.**”- It is necessary to check if the sensor protruding from the bottom of the casing is damaged.

CAUTION



The device is designed for single-phase installation and must be installed in accordance with standards valid in a particular country. The device should be connected according to the details included in this operating manual. Installation, connection and control should be carried out by a qualified electrician staff, who act in accordance with the service manual and the device functions.
In case of casing dismantling an electric shock may occur, and the guarantee is lost then. Before installation make sure the connection cables are not under voltage. The cruciform head screwdriver 3,5 mm should be used to mount the device. Improper transport, storage, and use of the device influence its wrong functioning. It is not advisable to mount the device in the following cases: if any device part is missing or the device is damaged or deformed. In case of improper functioning of the device contact the producer.

WARRANTY CARD

There is 24 months guarantee on the product

1. ZAMEL Sp. z o.o. assures 24 months guarantee for the product.
2. The manufacturer's guarantee does not cover any of the following actions:
 - a) mechanical damage during transport, loading / unloading or under other circumstances,
 - b) damage caused by incorrect product mounting or misuse,
 - c) damage caused by unauthorised modifications made by the PURCHASER or any third parties to the product or any other devices needed for the product functioning,
 - d) damage caused by Act of God or any other incidents independent of the manufacturer - ZAMEL Sp z o.o.
 - e) supply sources (batteries) included in the device during selling (if they are included).
3. The PURCHASER shall lay any claims in writing to the dealer or ZAMEL Sp. z o.o.
4. ZAMEL Sp. z o.o. is liable for processing any claim according to current Polish legislation.
5. ZAMEL Sp. z o.o. shall process the claim at its own discretion: product repair, replacement or money return.
6. The manufacturer's guarantee is valid in the Republic of Poland.
7. The PURCHASER's statutory rights in any applicable legislation whether against the retailer arising from the purchase contract or otherwise are not affected by this warranty.

Salesman stamp and signature, date of sale

Temperature Regulator RTD-01

MANUAL INSTRUCTION

zameL

ZAMEL Sp. z o.o.

ul. Zielona 27, 43-200 Pszczyna, Poland
tel. +48 32 449 15 00, +48 32 210 46 65, fax +48 (32) 210 80 04
www.zamel.com, e-mail: marketing@zamel.pl



TECHNICAL PARAMETERS

Supply terminals:	N (1), L (2)
Power supply voltage:	100÷240 V AC
Nominal frequency:	50/60 Hz
Nominal power consumption:	1,5 W (STANDBY)
Battery backup:	no
NTC sensor terminal:	(6), (7)
Temperature sensor:	NTC 10k lub 100k dla 25°C
Room temperature range:	+5 ÷ +35°C
Floor temperature range:	+5 ÷ +40°C
Operating temperature range:	0 ÷ +50°C
Temperature range during transport :	-10 ÷ +60°C
Temperature measuring accuracy:	±0,5°C
Output terminals:	(3), (4)
Type of output:	voltage contact 1NO-16 A / 250 V AC
Number of connecting cables:	7
Cross section of connecting cables:	0,5 ÷ 2,5 mm ²
Humidity:	<90%, without condensation
Mounting:	deeper junction box ø 60 mm x 60 mm
Casing material:	engineering plastic, PC
Casing protection degree:	IP21
Protection class:	II
Overvoltage category:	II
Nominal surge voltage:	2500 V
Pollution level of a regulator:	3 A level
Application environment:	2 pollution degree (domestic application with standard air circulation)
Ball pressure temperature:	125°C
Dimensions:	81,5 x 81,5 x 21/41 mm (height x width x depth)
Weight:	130 g
Reference standard:	PN-EN 60730-1:2012 PN-EN 60730-2-9:2011 PN-EN 55014-1 PN-EN 55014-2 PN-EN 61000-3-2 PN-EN 61000-4-3 PN-EN 61000-4-11 PN-EN 61000-4-6

DESCRIPTION

The temperature regulator RTD-01 is a 7-day programmable regulator designed for electric floor heating systems. It is operated by means of a touch screen.

The regulator is mounted on a wall in a junction box ø60 x 60 mm. It is compatible with floor sensors: SASWELL 100k, SASWELL 10k, DEVI 15k, OJ12k, Eberle 33k, Ensto 47k, FENIX 10k, TYCO 10k Teplolux 6k, Warmup 12k, Aube 10k.

FEATURES

- 2,4" LCD display of 320x240 pxl resolution
- Adjustment by means of a touch screen
- Energy monitoring function
- Anti frost protection function
- Menu includes 11 languages: English, French, German, Dutch, Russian, Polish, Norwegian, Swedish, Danish, Finnish, Romanian.
- Cooperation with NTC sensor of different manufacturers
- Blockades against children
- Holiday mode (holiday)

USAGE / MOUNTING SAFETY

- 1 The device should be connected to a single phase in accordance with the standards applicable in the country.
- 2 The wiring diagram is specified in this manual instruction.
- 3 Activities connected with mounting, connection and adjustment should be performed by a qualified electrician, who is familiar with the instruction and functions of the device.
- 4 Casing disassembly will void the warranty and can cause electric shock.
- 5 Before mounting, disassembly, cleaning or servicing operations power supply should be switched off from the mains and make sure that the connection cables are not under voltage.
- 6 For mounting a screwdriver with a flat bit with a diameter of 3,5 mm should be used.
- 7 Transport, storage and use of the device, in particular mounting of the regulator and the temperature sensor, have an influence on its proper operation.
- 8 Mounting the device in case of lacking of components, device damage or deformation is strongly prohibited.
- 9 In case of improper operation contact with the producer.
- 10 The regulator must not be covered and no elements or items can be hang on it (e.g. a towel).
- 11 Do not pour any liquids on the regulator.
- 12 Do not interrupt the power supply of the temperature regulator. It can cause switching off the backlight of the screen and heating control. The entered regulator's adjustments will be saved.
- 13 The control and operation of the regulator by children or persons with physical, sensory or mental problems is strongly forbidden.
- 14 The regulator should be protected from shock and damage.

REGULATOR'S MOUNTING PLACE

The regulator is designed to be used in an environment of two degree of contamination, i.e. to be used in domestic conditions with standard air circulation.

- 1 The regulator should be mounted in a heated room – in a deep junction box $\phi 60 \times 60$ mm at a height of 120 cm from the heated floor surface.
- 2 The regulator should be installed in a place not exposed to direct sunlight and in a little airy places.
- 3 Temperature and humidity in the mounting place should not exceed values given in technical parameters ($0 < T < 50^\circ\text{C}$, humidity RH > 90%).

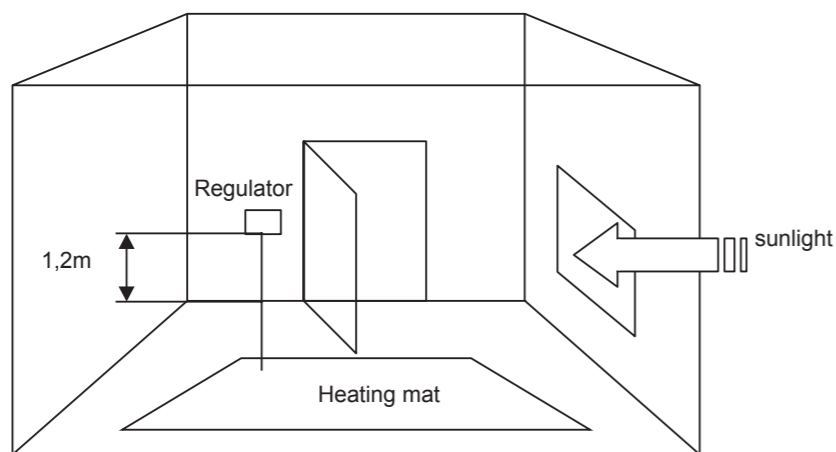

An example of mounting RTD-01 regulator

CONNECTION DIAGRAM

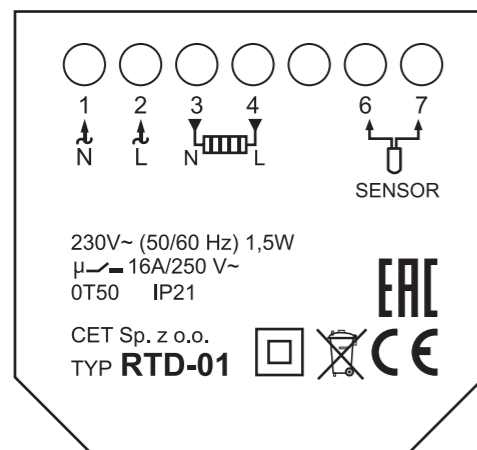

L – phase wire
 N – neutral wire
 pos.3-4 - loading
 pos. 5 – control input (Clock) – function not to be used in case of RTD-01
 pos. 6-7 – floor sensor

PROGRAMME SETTINGS

Menu → Programme (Set program day). Choose the days of the week the changes will be made for → **Next** (by means of arrows up / down) set the time and temperature zones). Confirm by **OK**.
 Setting interface; There are 6 periods: morning, leaving home in the morning, returning in the noon, leaving home in the afternoon, returning home in the evening and at night. Changes for 7 days can be made at the same time. Grey backlight of the days of the week means changes in this operation cannot be made. It can be done after another entry into the Program.

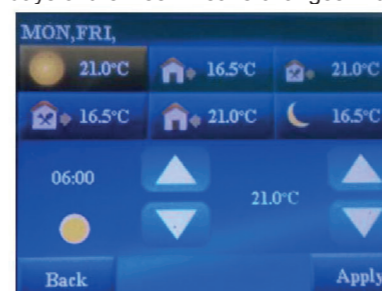

Default settings of a period and temperature are as follows:

Days of the week	☀		🏠		👤		👤		🏠		🌙	
	Time	Temp.	Time	Temp.	Time	Temp.	Time	Temp.	Time	Temp.	Time	Temp.
All 7	6:00	21 °C	8:00	16,5°C	12:00	21 °C	14:00	16,5°C	18:00	21 °C	22:00	16,5°C

ENERGY COST REVIEW

Menu → Energy → Cost and chose an appropriate period on the screen (today, yesterday, current day, current week, current month, current year). Choose e.g. **This week** → **Next**.
 Estimated energy cost will be precise after heating cost adjustment.

ENERGY PARAMETERS SETTING

Menu → Energy → Load. In this interface data can be entered subsequently into **Load Sett and Tariff Sett** → **NEXT** and **APPLY**.
 In each interface the adjustments should be entered.



TEMPERATURE UNIT SETTING

Menu → Setting → Scale → choose 0°C or 0°F and **Apply**.

SCREEN BACKLIGHT SETTING

Menu → Setting → Video. In this interface the preferences should be chosen: background (black or blue), screen brightness (3-2-1), stand-by brightness (3-2-1-0), parental control (switch on/switch off). Other functions should be chosen by **Next** and at the end confirm by **OK**.

CHOICE OF TEMPERATURE MEASURING METHOD

Menu → Setting → Sensors mode. One method of measuring and control should be chosen (1. Room, 2. Floor, 3. All)

1. **Room;** Room sensor (internal); The regulator will read temperature from this sensor and will control the room temperature
2. **Floor;** External floor sensor (cable with a sensor).The regulator will read floor temperature from this sensor and will control its temperature.
3. **All;** In this system the internal sensor is used to measure and control room temperature and the external sensor protects the floor against overheating. If the floor temperature reaches the upper limit, the regulator will switch off the heating till the floor temperature drops beneath the adjusted value.