

MAGNUM ETOR-55

Sensor for MAGNUM Outdoor systems

Gutter sensor type ETOR-55 + 10 metres connection cable

Designed for mounting in gutters and down pipes ect. Detects moisture and is mounted in combination with outdoor sensor ETF for temperature detection. Only to be used in combination with outdoor sensor type ETF-744/99.

Mounting of sensor

To be mounted in the gutter or downpipe on the sunny side of the building. Contact points of the sensor must be placed towards the flow of the melting water. To be mounted where the melting water will often appear.

Mounting of sensor cable

The cable must be mounted in accordance with applicable local regulations. The cable must never be installed parallel to power cables as electrical interference may distort the sensor signal. The sensor is supplied with 10 m cable which can be extended up to 200 m using standard installation cable: 6 x 1,5 mm². The total resistance of the cable must be less than 10 ohm.

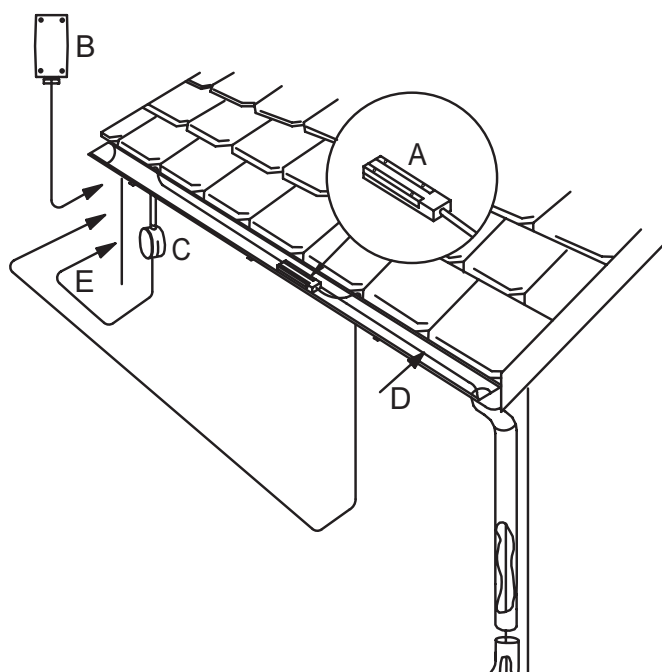
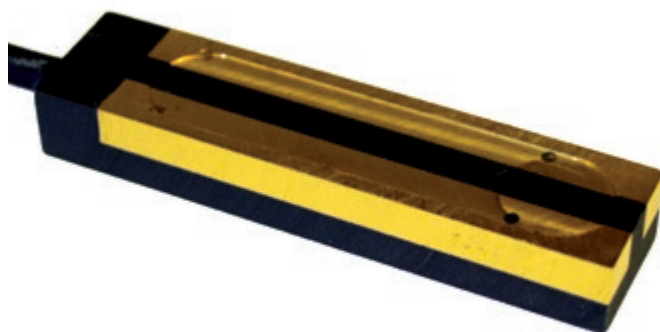

Specifications

Measurement	Moisture
Installation	Gutter or downpipe
Housing	IP68
Temp. range (ambient)	-50°C / +70°C
Dimensions	105/30/13 mm (H/W/D)



Art.nr.	Description
900055	MAGNUM Sensor unit ETOR-55 moisture for the (roof) gutter