

Type ETO2 Controller for ice and snow melting



English

Type ETO2 is an electronic controller for fully automatic, economical ice and snow melting on outdoor areas and in gutters. Ice forms due to a combination of low temperature and moisture. ETO2 detects both temperature and moisture, and the snow melting system will usually only be activated if snow or ice is present. ETO2 is suitable for controlling electric heating cables, or water-based heating pipes.

Product program

ETO2-4550-xxxx	Thermostat.
ETOG-55-xxxxx	Ground sensor for detecting temperature and moisture.
ETOR-55-xxxxx	Gutter sensor for detecting moisture.
ETF-744/99	Outdoor sensor for detecting temperature



WARNING! – Read this manual!
Carefully read this instruction manual in its entirety, paying close attention to all warnings listed below. Make sure that you fully understand the use, displays and limitations of the controller, because any confusion resulting from neglecting to follow this instruction manual, or from

improper use of this device, may cause an installer to commit errors, that may lead to ice & snow conditions resulting in serious injury or death.



WARNING! – Be aware that snow, ice and iceicles may be present even if you follow the instruction or manual.

You are strongly advised to follow any unexpected build-up of snow, ice layers or icicles. As an additional safety measure, you should always perform a manual inspection of public areas in order to secure safety for access of the controlled areas.



WARNING! – Important safety instructions.
Disconnect the power supply before carrying out any installation or maintenance work on this control unit and associated components. This control unit and associated components should only be installed by a competent person (i.e. a qualified electrician). Electrical installation must be in accordance with appropriate statutory regulations.

CE MARKING, FOR EU

OJ Electronics A/S hereby declares that the product is manufactured in accordance with Council Directive

2004/108/EC on electromagnetic compatibility (and subsequent amendments) and Council Directive 2006/95/EEC on electrical equipment designed for use within certain voltage limits.

Applied standards

ETO2-4550-EU28: CE marking LVD/EMC: EN60730-2-9

ETO2-4550-US28: CAN/CSA E 60730-2-9:01.

ETO2-4550-RU28: CE marking LVD/EMC: EN60730-2-9

The product may only be used if the complete installation complies with current directives.

The product carries a manufacturer's warranty if installed in accordance with these instructions and current regulations.

If the product has been damaged in any way, e.g. during transport, it must be inspected and checked by authorised personnel before being connected to the power supply.

Technical data

Thermostat ETO2-4550:

Designed to be mounted indoor only!

Supply voltage115/240V AC \pm 10%, 50-60 Hz

Built-in electronic power supply (SMPS) . . .24 V DC, 8 VA
 3 output relays (potential-free contact, NO)3 X 16 A
 Alarm relay (potential-free contact, NO)max. 5 A
 Control signal to actuator (mixing valve)0-10 V DC
 Supply voltage to actuator
 (mixing valve)24 V AC / 100 mA
 On/off differential1.8°F / 1°C
 Temperature range-4/+50°F / -20/+10°C
 Ambient temperature32/122°F / 0/+50°C
 Ambient air humidity10-95%
 Enclosure ratingIP 20 / Nema 1
 Weight600 g
 Dimensions H/W/D90/156/45 mm

Type 1B

Control pollution degree 2

Rated impulse voltage4 kV

Ground sensor type ETOG-55:

Designed to be embedded in outdoor areas.

DetectionMoisture and temperature

MountingOutdoor area

Enclosure ratingIP 68

Ambient temperature-57/+158°F / -50/+70°C

DimensionsH32, Ø60 mm

Gutter sensor type ETOR-55:

Designed to be mounted in gutter or downpipe. Is used together with outdoor sensor type ETF.

Detection	Moisture
Mounting	Gutter or downpipe
Enclosure rating	IP 68
Ambient temperature	-57/+158°F / -50/+70°C
Dimensions H/W/D	105/30/13 mm

Outdoor sensor type ETF-744/99:

Detection	Temperature
Mounting	Wall
Ambient temperature	-57/+158°F / -50/+70°C
Dimensions H/W/D	.86/45/35 mm

Water sensor type ETF-1899A:

Detection	Temperature
Mounting	Strap on pipe
Ambient temperature	-4/+158°F / -20/+70°C
Dimensions H/W/D	.86/45/35 mm

The snow and ice melting system is deactivated in the event of sensor failure.

SENSOR INSTALLATION**Ground sensor ETOG, fig. 1+3:**

For installation on outdoor areas where snow and ice is a regular problem. The sensor must be embedded horizontally with its top flush with the surroundings. Use the accompanying installation plate.

The sensor cable must be installed in accordance with current regulations. We recommend that cable pipes be laid to protect the sensor cable. Detailed installation instructions are supplied with the sensor.

Gutter sensor ETOR, fig. 2+4:

For installation in a gutter, or downpipe on the sunny side of the building. It is important to ensure that the sensor contact elements face against the flow of melt water. If necessary, two sensors can be installed in parallel. Detailed installation instructions are supplied with the sensor.

Note that the pink and grey wires are not used.

Outdoor sensor ETF-744/99, fig. 2+4:

ETF is for use with gutter sensor ETOR. ETF can also be used separately for the detection of temperature alone. The sensor should be mounted on the wall beneath the eaves on the north side of the building.

Water sensor type ETF-1899A:

Only for use in waterbased system to detect temperature in supply and return water. Must be fastened with strips fixed directly on the pipe.

Sensor cables:

ETOG and ETOR are supplied with 10 m cable, which can be extended up to approx. 200 m using standard installation cable: 6x1.5 mm² for ETOG and 4x1.5 mm² for ETOR. The ETF cable can be up to approx. 50 m in length. Sensor cables must be installed in accordance with current regulations. They must never be installed parallel to power cables as electrical interference may distort the sensor signal.

ETO2 installation

The unit is intended to be DIN-rail mounted in an approved panel.

Wall mounting:

For USA and Canada: The thermostat can be wall-mounted in a specially designed and UL-approved metal box (accessory).

For other countries: The accompanying plastic cover can be used for wall mounting in an indoor area.

Connect supply voltage to terminals N and L. All electrical and mechanical installation must be performed in accordance with applicable local regulations.

Setup:

- **1-zone electric heating control with ETOG (fig. 3+6):**
Connect 1 or 2 ETOG sensors to terminals 11-20.
Connect heating cable to output relays 1, 2 and 3 according to fig. 8.
- **1-zone electric heating control with ETOR + ETF (fig. 4+7):**
Connect 1 or 2 ETOR sensors to terminals 11-20. Note that the pink and grey wires are not used.
Connect 1 ETF sensor to terminals 31-32.
Connect heating cable to output relays 1, 2 and 3 according to fig. 8.

- **2-zone electric heating control with ETOG (fig. 6):**
Connect 2 ETOG sensors to terminals 11-20.
Connect heating cable for zone 1 to output relay 1 according to fig. 8.
Connect heating cable for zone 2 to output relay 2 according to fig. 8.
- **2-zone electric heating control with ETOR (fig. 7):**
Connect 2 ETOR sensors to terminals 11-20. Note that the pink and grey wires are not used.
Connect heating cable for zone 1 to output relay 1 according to fig. 8.
Connect heating cable for zone 2 to output relay 2 according to fig. 8.
- **2-zone electric heating control with ETOR and ETOG (fig. 5+6+7):**
Connect 1 ETOR sensor to terminals 11-16 as sensor
1. Note that the pink and grey wires are not used.
Connect 1 ETOG sensor to terminals 11-20 as sensor
2. Connect heating cable for zone 1 (roof) to output relay 1 according to fig. 8.
Connect heating cable for zone 2 (ground) to output relay 2 according to fig. 8.
- **1-zone electric heating control and output control (Y/ Δ) (fig. 9+10):**
Advanced 2-step control with ETOG-55. 1/3 power on heating cables in afterrun.
Connect 1 or 2 ETOG sensors to terminals 11-20.
Connect external contactor/relays to output relays 1, 2 and 3 according to fig. 10.
- **1-zone hydronic heating control for control of supply water temp. with mixing valve (fig. 6+11):**
Connect 1 or 2 ETOG sensor to terminals 11-16.
Connect supply voltage (24 V AC) for mixing valve to terminals 25-26 (fig. 13)
Connect mixing valve to terminals 21-24 (fig. 13).
Connect ETF 1899A supply and return sensors to terminals 27-30.
Connect primary pump to output relay 1 according to fig. 14.
Connect secondary pump to output relay 2 according to fig. 14.

- **1/2-zone hydronic heating control, simple (fig. 6+12):**
Connect 1 or 2 ETOG sensors to terminals 11-20.
Connect circulation pump for zone 1 to output relay 1 according to fig. 14.
If zone 2 is used, connect circulation pump for zone 2 to output relay 2 according to fig. 14.
Application setup as for 1/2-zone electric heating control, see User Manual, Startup.
- **Remote control (fig. 15):**
The forced heat and standby functions can be remotely controlled by wiring ETO2 to external buttons/relays (normally open).
Connect external standby button to terminals 33-34.
Connect external forced heat button to terminals 35-36.

TESTING SNOW MELTING SYSTEM

After completing installation and application setup, it is recommended that the snow melting system be tested.

1. Adjust SET TEMP in the setup menu to max. temperature.
2. Pour some water onto the sensor (ETOG/ETOR).
3. The output relay for the heating cable in the zone concerned should activate and ON should be indicated on the ETO2 display. Check that the heating cable becomes warm, check the voltage if possible.
4. After testing, adjust SET TEMP back to the desired setting (factory setting = +3.0°C / 37.4°F).

WIRING

Terminal	Colour code	Wiring
N, L		Supply voltage, 120-240 V AC 50/60 Hz
1, 2		Alarm relay (potential free) max. 5 A
3, 4		Output relay 1, 16 A (potential free), Heating cable 1 (zone 1) / Primary pump
5, 6		Output relay 2, 16 A (potential free), Heating cable 2 (zone 2) / Secondary pump
7, 8		Output relay 3, 16 A (potential free), Heating cable 3
11, 12	brown/green	Sensor heating 1+2, ETOG 1+2 and ETOR 1+2
13, 14	grey/pink	Temperature sensor, ETOG 1
15, 16	yellow/white	Moisture sensor 1, ETOG 1/ ETOR 1
17, 18	grey/pink	Temperature sensor, ETOG 2
19, 20	yellow/white	Moisture sensor, ETOG 2 / ETOR 2
21, 22		3/4-way mixing valve, 0-10 V
23, 24		3/4-way mixing valve, 24 V AC
25, 26		24 V AC from external supply, for 3/4-way mixing valve



ETOR SENSOR WIRES : Note that the pink and grey wires are not used.

Terminal	Colour code	Wiring
27, 28		Supply water temperature sensor, ETF-1899A
29, 30		Return water temperature sensor, ETF-1899A
31, 32		Outdoor temperature sensor, ETF
33, 34		Standby, external input
35, 36		Forced control heat, external input

Environment protection and recycling

Help protect the environment by disposing of the packaging and redundant products in a responsible manner.

Product disposal

Products marked with this symbol must not be disposed of along with household refuse, but must be delivered to a waste collection centre in accordance with current local regulations.



Figures

- Fig. 1 Installation of ETOG ground sensor
 - 1 Sensor
 - 2 Installation plate
 - 3 Heating element
- Fig. 2 Installation of ETOR gutter sensor and ETF outdoor sensor
 - 1 Thermostat ETO2
 - 2 Gutter sensor
 - 3 Outdoor sensor
- Fig. 3 One-zone electric heating with ETOG sensor
- Fig. 4 One-zone electric heating with ETOR/ETF sensor
- Fig. 5 Two-zone electric heating (roof/ground)
- Fig. 6 ETOG connection
- Fig. 7 ETOR connection
- Fig. 8 Heating cable connection, example
- Fig. 9 Two-stage electric heating control (Y/Δ)
- Fig. 10 Advanced 2-step connection Y/Δ
- Fig. 11 Hydronic heating with mixing valve
- Fig. 12 Simple hydronic application
- Fig. 13 Hydronic mixing valve connection
- Fig. 14 Hydronic pump connection
- Fig. 15 Connections for remote control of standby and forced heat
- Fig. 16 ETO2 controller, terminal overview

ETO2

Fig. 1 ETOG-55 Installation

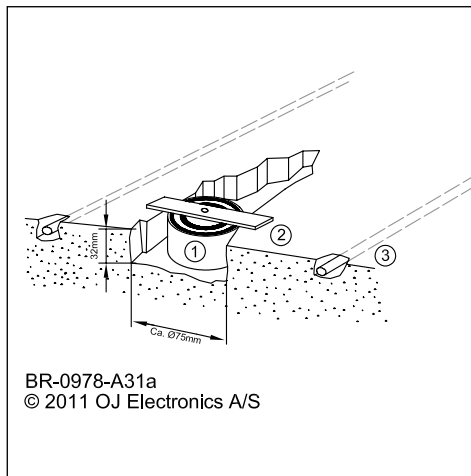
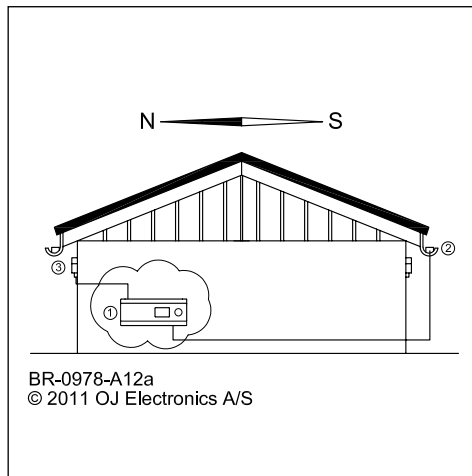

Fig. 2 ETOR-55 Installation



ETO2

Fig. 3 Electric 1-zone with ETOG-55 sensor

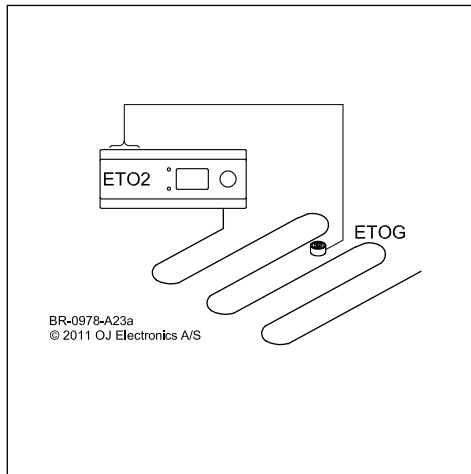
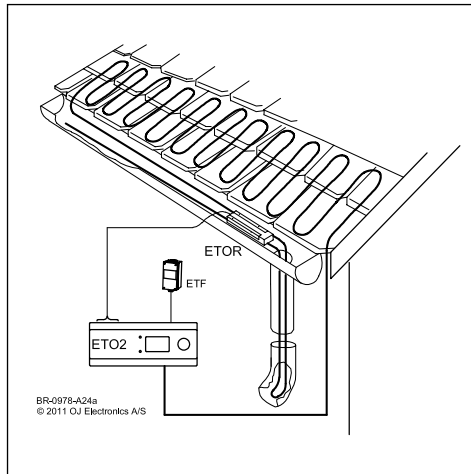

Fig. 4 Electric 1-zone with ETOR-55 / ETF



ETO2

Fig. 5 Electric 2-zone with ETOG, ETOR and ETF

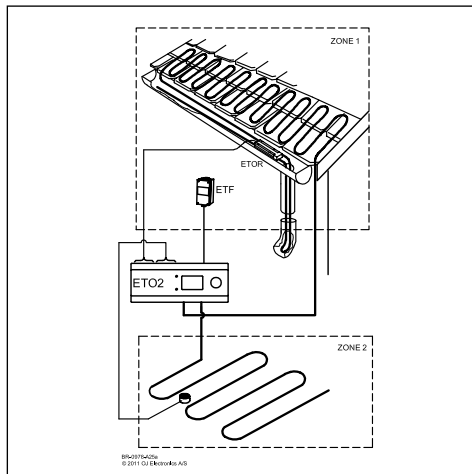
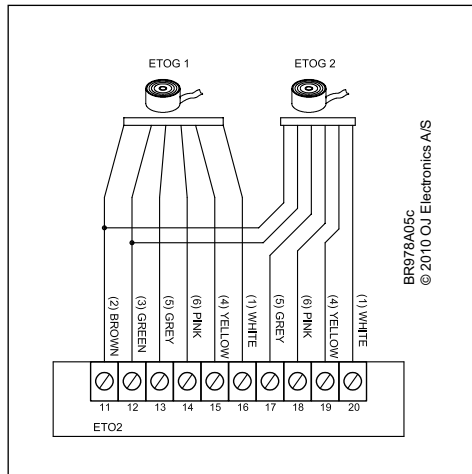

Fig. 6 ETOG-55 connections



ETO2

Fig. 7 ETOR-55 connections

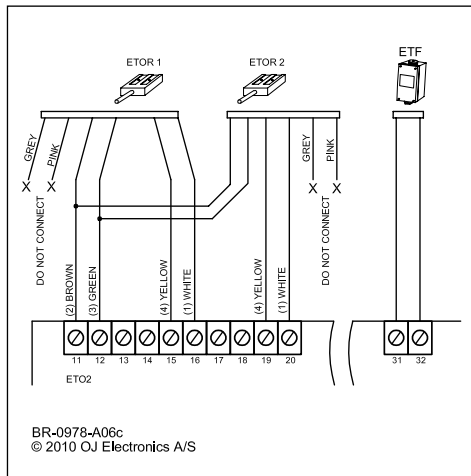
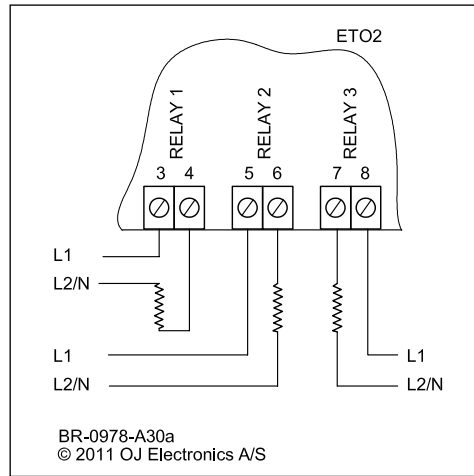

Fig. 8 Electric heating cable connections



ETO2

Fig. 9 Advanced 2-step with ETOG-55. 1/3 power on heating cables in afterrun.

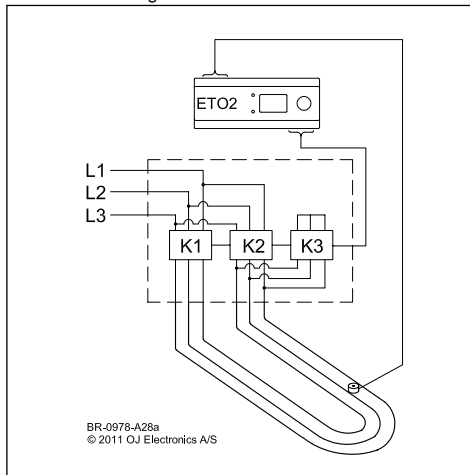

Fig. 10 Advanced 2-step connections. 1/3 power on heating cables in afterrun.

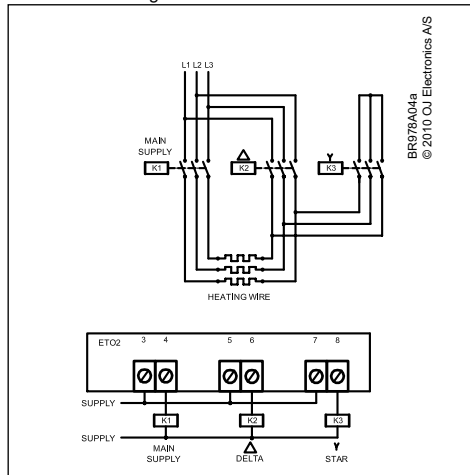

Fig. 11 Hydronic heating with mixing valve

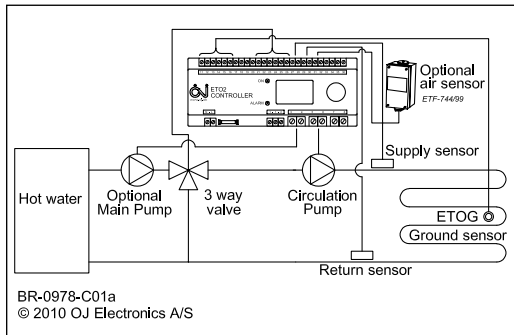
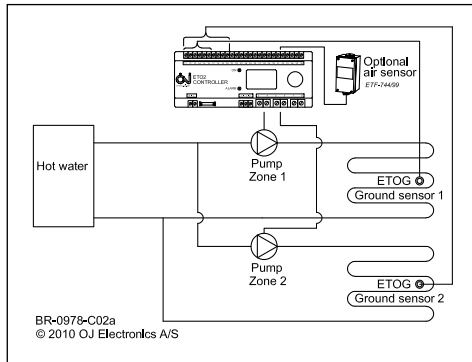

Fig. 12 Hydronic, simple application



ETO2

Fig. 13 Hydronic mixing valve connection

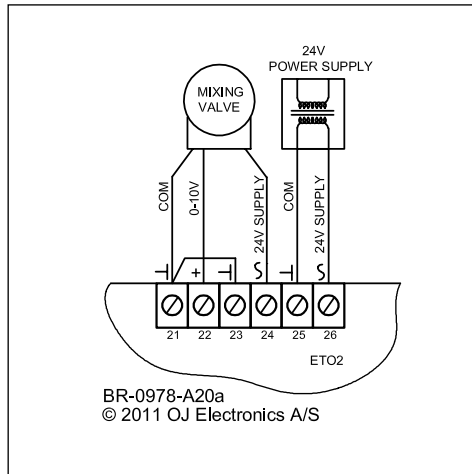

Fig. 14 Hydronic pump connection

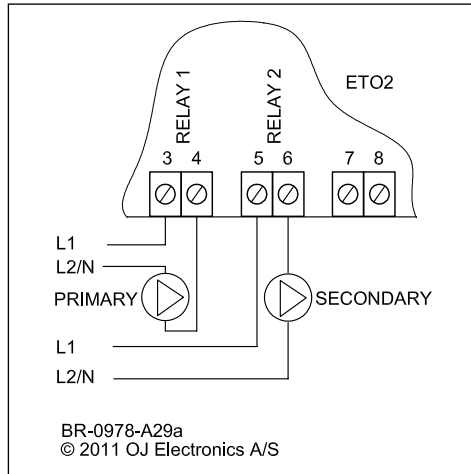
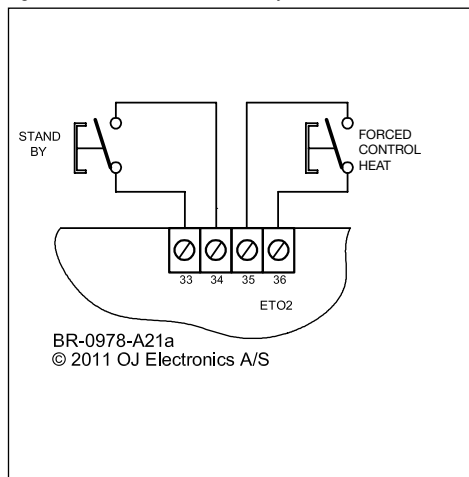
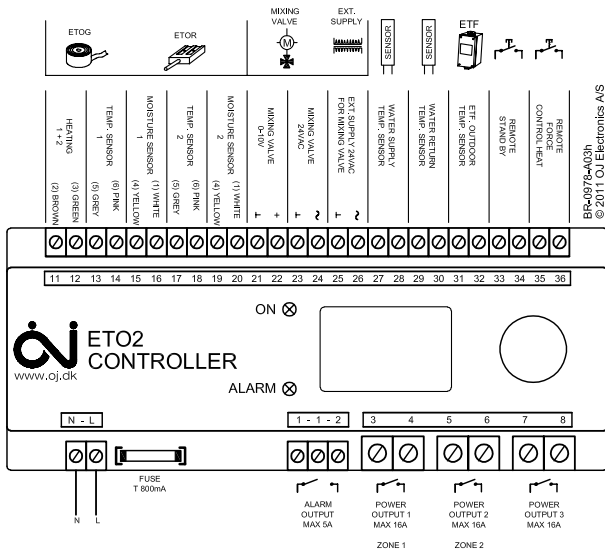

Fig. 15 Connection of Stand by & forced heat



ETO2

Fig. 16



ETO2